

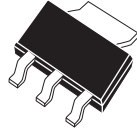

CZT3090LE

**ENHANCED SPECIFICATION
SURFACE MOUNT
LOW $V_{CE(SAT)}$
NPN POWER TRANSISTOR**

**ENHANCED
SPECIFICATION**



SOT-223 CASE

APPLICATIONS:

- Power Management / DC-DC Converters
- Portable and Battery Powered Products
- LAN Equipment / Motor Controllers

MAXIMUM RATINGS: ($T_A=25^\circ\text{C}$)

- ◆ **Collector-Base Voltage**
- ◆ **Collector-Emitter Voltage**
Emitter-Base Voltage
- Continuous Collector Current
- Peak Pulse Current
- Power Dissipation
- Operating and Storage Junction Temperature
- Thermal Resistance

ELECTRICAL CHARACTERISTICS: ($T_A=25^\circ\text{C}$)

SYMBOL	TEST CONDITIONS	MIN	TYP	MAX	UNITS
◆ I_{CBO}	$V_{CB}=50V$			50	nA
◆ I_{EBO}	$V_{EB}=5.0V$			50	nA
◆ BV_{CBO}	$I_C=100\mu A$	60			V
◆ BV_{CEO}	$I_C=10mA$	50			V
BV_{EBO}	$I_E=10\mu A$	6.0			V
$V_{CE(SAT)}$	$I_C=100mA, I_B=1.0mA$		37	50	mV
◆ $V_{CE(SAT)}$	$I_C=1.0A, I_B=20mA$		66	100	mV
◆ $V_{CE(SAT)}$	$I_C=2.0A, I_B=200mA$		77	150	mV
◆ $V_{CE(SAT)}$	$I_C=3.0A, I_B=60mA$		155	250	mV
◆ h_{FE}	$V_{CE}=2.0V, I_C=500mA$	300			
◆ h_{FE}	$V_{CE}=2.0V, I_C=1.0A$	300			
h_{FE}	$V_{CE}=2.0V, I_C=3.0A$	150	174		
◆ C_{ob}	$V_{CB}=10V, I_E=0, f=1.0MHz$			25	pF
f_T	$V_{CE}=10V, I_C=500mA$	100			MHz

◆ Enhanced Specification

**Central™
Semiconductor Corp.**

DESCRIPTION:

The CENTRAL SEMICONDUCTOR CZT3090LE is an Enhanced Specification Low $V_{CE(SAT)}$ NPN Silicon Power Transistor packaged in an industry standard SOT-223 case. High Collector Current, coupled with a Low Saturation Voltage, make this an excellent choice for industrial and consumer applications where electrical and thermal operational efficiency are top priorities.

MARKING: FULL PART NUMBER

FEATURES:

- Low $V_{CE(SAT)}$ NPN Transistor
- High Current ($I_C=3.0A$ MAX)
- $V_{CE(SAT)}=0.155V$ TYP @ $I_C=3.0A$
- SOT-223 Surface Mount Package
- Complementary PNP device **CZT7090LE**

SYMBOL		UNITS
V_{CBO}	60	V
V_{CEO}	50	V
V_{EBO}	6.0	V
I_C	3.0	A
I_{CM}	5.0	A
P_D	2.0	W
T_J, T_{stg}	-65 to +150	$^\circ\text{C}$
θ_{JA}	62.5	$^\circ\text{C/W}$

MIN	TYP	MAX	UNITS
		50	nA
		50	nA
60			V
50			V
6.0			V
	37	50	mV
	66	100	mV
	77	150	mV
	155	250	mV
300			
300			
150	174		
		25	pF
100			MHz

**ENHANCED SPECIFICATION
SURFACE MOUNT
LOW $V_{CE(SAT)}$
NPN POWER TRANSISTOR**

SOT-223 CASE - MECHANICAL OUTLINE

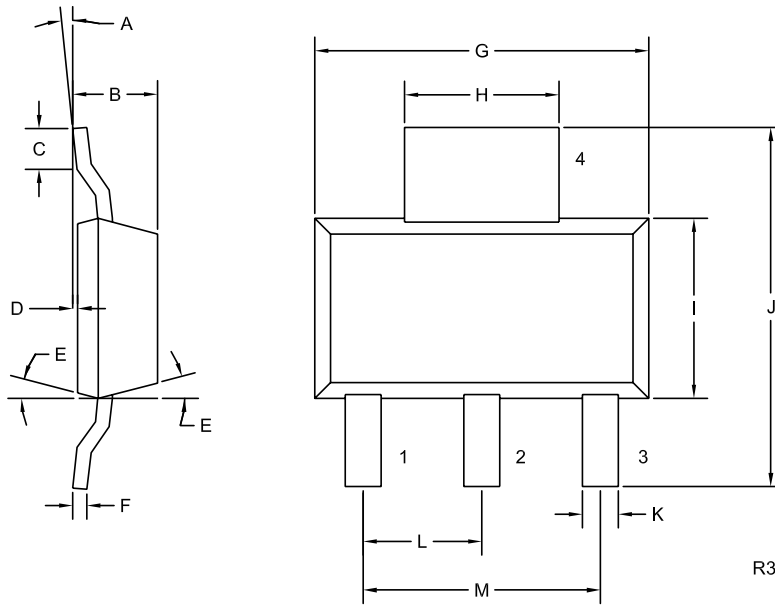

LEAD CODE:

- 1) BASE
- 2) COLLECTOR
- 3) EMITTER
- 4) COLLECTOR

MARKING:

FULL PART NUMBER

SYMBOL	DIMENSIONS			
	INCHES		MILLIMETERS	
	MIN	MAX	MIN	MAX
A	0°	10°	0°	10°
B	0.059	0.071	1.50	1.80
C	0.018	---	0.45	---
D	0.000	0.004	0.00	0.10
E	15°		15°	
F	0.009	0.014	0.23	0.35
G	0.248	0.264	6.30	6.70
H	0.114	0.122	2.90	3.10
I	0.130	0.146	3.30	3.70
J	0.264	0.287	6.70	7.30
K	0.024	0.033	0.60	0.85
L	0.091		2.30	
M	0.181		4.60	

SOT-223 (REV: R3)